



FPZ, Inc
 150 N. Progress Drive
 Saukville, WI 53080 - U.S.A.
 Tel. (262) 268-0180
 Fax (262) 268-0415
 E-mail usa@fpz.com

REGENERATIVE BLOWERS - PRESSURE
SCL K07 / K08 / K09 / K10 / K11 / K12

MS SERIES - MOR RANGE
 SN 1805-12 1/2

TECHNICAL CHARACTERISTICS

- Aluminium alloy construction
- Smooth operation
- High efficiency impeller
- Maintenance free
- Mountable in any position
- Recognized TEFC - cURus motor

OPTIONS

- Special voltages (IEC 38)
- Surface treatments

ACCESSORIES

- Inlet and/or inline filters
- Additional inlet/outlet silencers
- Safety valves
- Flow converting device
- Optional connectors

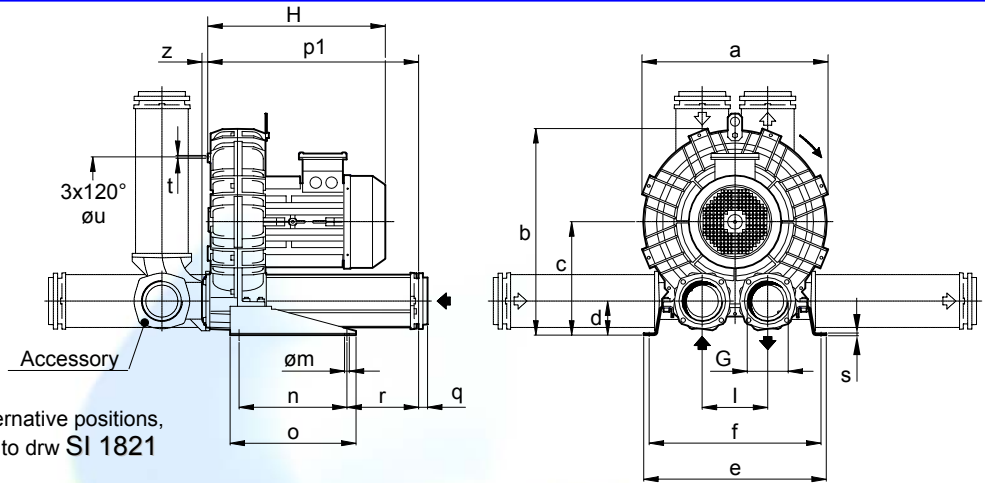

Possible alternative positions,
 please refer to drw SI 1821

Dimensions in inches.
 Dimension for reference only.

Model	a	b	c	d	e	f	G	l	m	n	o	p1	q	r	s	t	u	z
K07-MS	16.69	18.84	10.59	3.23	18.43	17.24	3" NPT	6.10	0.51	11.81	13.78	20.16	0.98	5.39	0.20	M8	11.61	0.63
K08-MS	17.99	19.61	10.59	3.23	18.82	17.64	3" NPT	6.10	0.51	11.81	13.78	20.16	0.98	5.39	0.20	M8	12.2	0.63
K09-MS	19.37	22.09	12.40	3.78	20.00	18.82	4" NPT	7.17	0.51	11.81	13.78	23.07	0.98	7.83	0.20	M8	14.17	0.63
K10-MS	20.31	22.56	12.40	3.78	20.00	18.82	4" NPT	7.17	0.51	11.81	13.78	23.07	0.98	7.83	0.20	M8	14.17	0.63
K11-MS	21.34	23.74	13.07	3.58	21.26	20.00	4" NPT	7.87	0.51	11.81	13.78	23.46	0.98	8.03	0.20	M8	15.35	0.63
K12-MS	21.57	23.82	13.07	3.58	21.26	20.00	4" NPT	7.87	0.51	11.81	13.78	23.58	0.98	8.03	0.20	M8	15.35	0.51

Model	Maximum flow Scfm		Installed power Hp		Maximum differential pressure Δp (In WG)		Noise level Lp dB (A) ⁽¹⁾		Overall dimensions H Inches	Weight Lbs
	60 Hz 3500 rpm	50 Hz 2900 rpm	60 Hz 3500 rpm	50 Hz 2900 rpm	60 Hz 3500 rpm	50 Hz 2900 rpm	60 Hz 3500 rpm	50 Hz 2900 rpm		
	K07-MS	294	243	4	4	50	63	78.7	76.7	15.45
K08-MS	381	316	5 1/2	5 1/2	75	86	79.0	77.0	15.45	107.10
			7 1/2	7 1/2	130	138	79.3	77.3	18.37	145.70
			10	10	181	161	79.6	77.6	18.37	154.50
			15	15	181	181	80.6	78.6	19.15	184.00
K09-MS	471	390	7 1/2	7 1/2	50	63	80.2	78.2	18.84	166.50
			10	10	80	95	80.5	78.5	18.84	175.10
			15	15	140	155	81.0	79.0	19.63	196.20
			20	20	181	181	81.3	79.3	23.74	269.00
K10-MS	556	460	7 1/2	7 1/2	36	51	80.1	78.1	18.84	170.90
			10	10	64	80	80.5	78.5	18.84	179.50
			15	15	120	135	81.0	79.0	19.63	200.60
			20	20	167	191	81.4	79.4	23.74	273.40
K11-MS	650	539	25	25	211	201	81.6	79.6	24.61	298.70
			10	10	40	53	82.0	80.0	19.04	194.90
			15	15	82	97	82.4	80.4	19.83	216.00
			20	20	125	141	82.7	80.7	23.94	288.80
K12-MS	726	602	25	25	162	201	85.6	83.6	24.81	313.10
			15	15	52	90	82.9	80.9	19.95	223.70
			20	20	85	130	83.2	81.2	24.06	296.50
			25	25	120	160	86.1	84.1	24.92	320.80

(1) Noise measured at 1 m distance with inlet and outlet ports piped, in accordance to ISO 3744.

- For proper use, the blower should be equipped with inlet filter and safety valve; other accessories available on request.
- Ambient temperature from +5° to +104°F.
- Specifications subject to change without notice.



REGENERATIVE BLOWERS - PRESSURE

SCL K07 / K08 / K09 / K10 / K11 / K12

MS SERIES - MOR RANGE

SN 1805-12 2/2

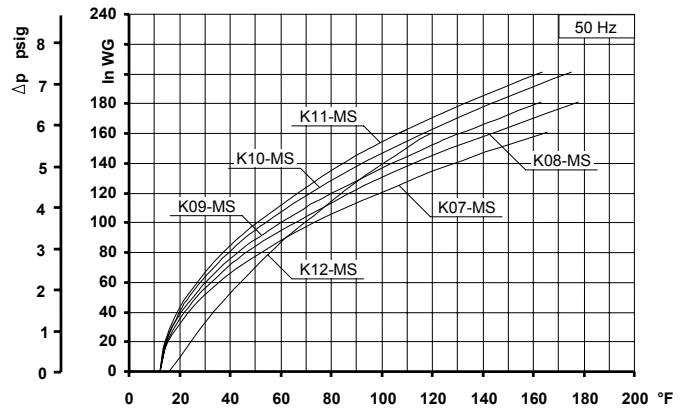
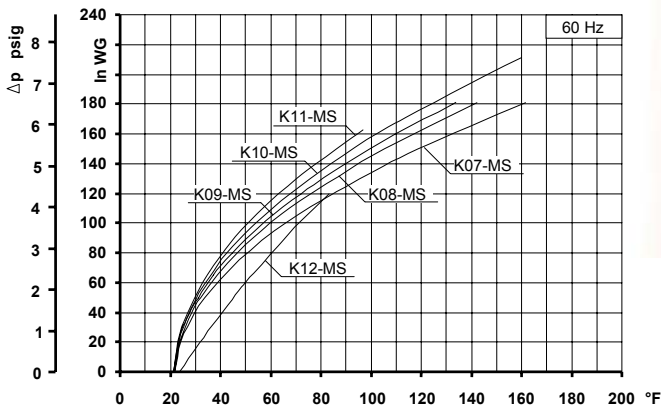
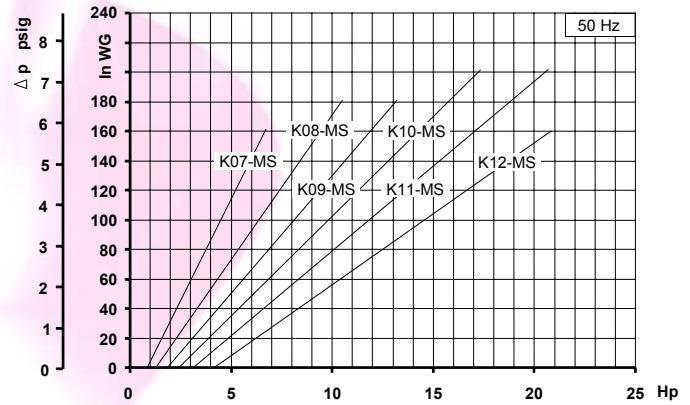
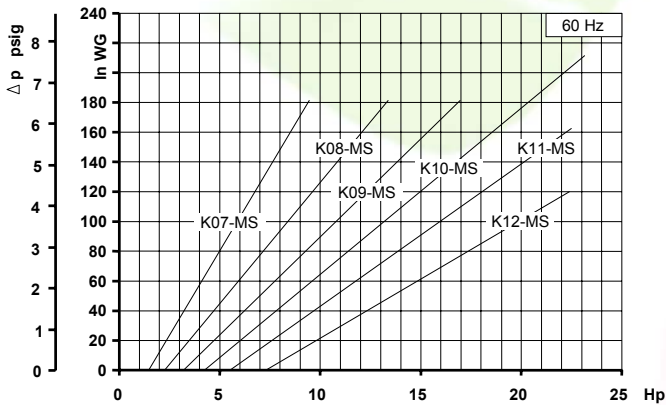
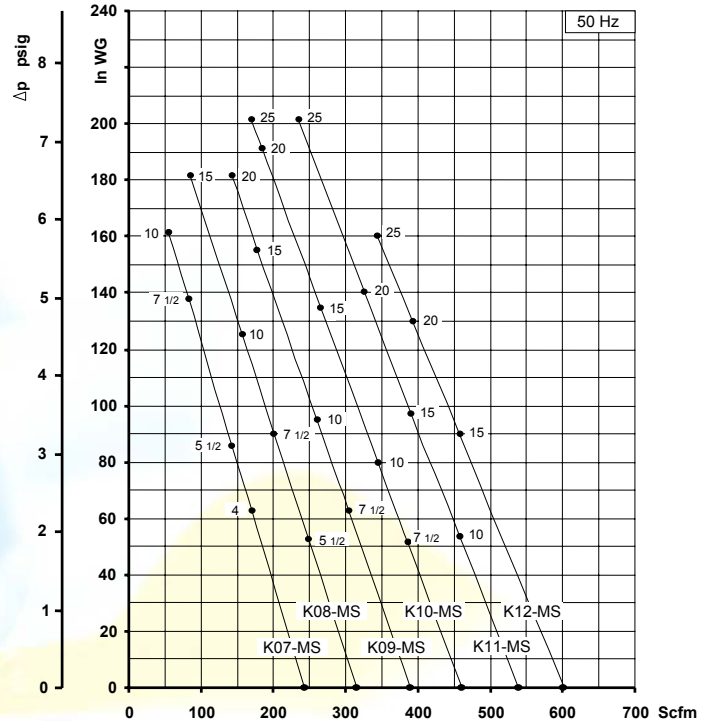
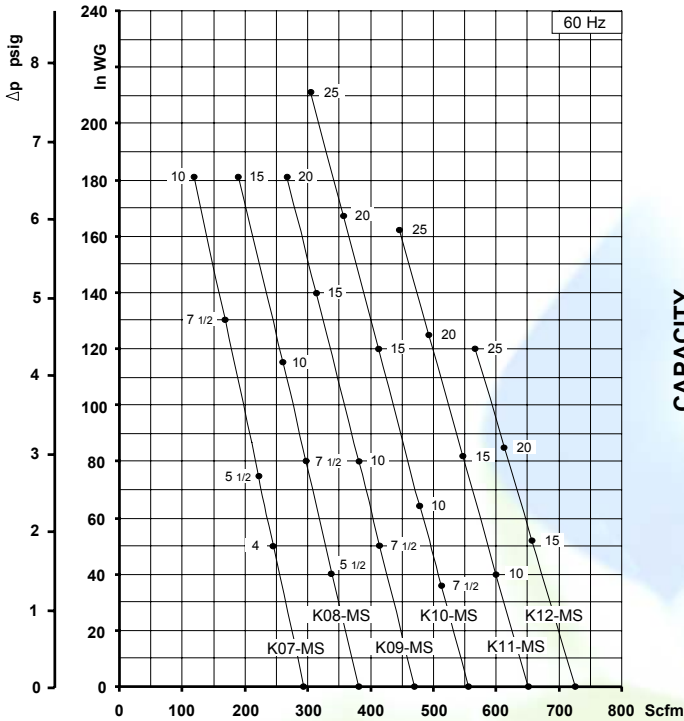

Curves refer to air at 68°F temperature and 29.92 In Hg atmospheric pressure (abs) measured at inlet port.
 Values for flow, power consumption and temperature rise: +/-10% tolerance.
 Data subject to change without notice.